



OWNER'S MANUAL

TRAILSAFE SERIES

MODELS TRAILSAFE
TRAILSAFE+



TEAMBMPRO.COM

SAFETY PRECAUTIONS

Please read the Safety Precautions before installing or using the TrailSafe or TrailSafe+. Be sure to observe all precautions without fail. Failure to observe these instructions properly may result in property damage or personal injury which, depending on the circumstances, may be serious and cause loss of life.

After completing installation of the TrailSafe or TrailSafe+, conduct a trial operation to check for faults. Refer to the **Initial Self-Test** section of this manual for information on how to check for faults.



WARNING



Correct installation is the most critical factor in ensuring the safe use of the TrailSafe. If every consideration of these instructions has been satisfied, the TrailSafe will be safe to operate.



Before wiring / servicing TrailSafe, disconnect it from all power sources.



The pull pin should be tested before use to confirm the switch function and battery status.



The TrailSafe is a high precision electronic product. It contains no user-serviceable parts inside. Do not try to dismantle, modify or repair it yourself. Disassembly, service or repair by an unauthorised person will void the warranty.



It is essential the house battery is well maintained and must have at least 50% of nominal capacity available.



It is essential all wiring is protected by fusing close to any power source.

MANUAL PART 039207
REV 6.0

Copyright © 2023

Designed by BM PRO, one of Australia's leading power solution experts, the BM PRO product range is proudly designed and manufactured in Melbourne, Australia, and represent a high-quality product that will provide years of service.

DISCLAIMER: BM PRO accepts no liability for any loss or damage which may occur from the improper or unsafe use of its products. Warranty is only valid if the unit has not been modified or misused by the customer.

CONTENTS

| | |
|--|------------|
| SAFETY PRECAUTIONS | .2 |
| ABOUT THE TRAILS SAFE | .4 |
| KEY FEATURES | 4 |
| VEHICLE STANDARDS | 4 |
| INSTALLATION INSTRUCTIONS | .5 |
| TRAILS SAFE WIRING INSTRUCTIONS | .6 |
| TRAILS SAFE WIRING DIAGRAM | 7 |
| TRAILS SAFE+ WITH SWAYCONTROL WIRING INSTRUCTIONS | .9 |
| TRAILS SAFE+ WITH SWAYCONTROL WIRING DIAGRAM | 11 |
| USING THE TRAILS SAFE | .13 |
| INITIAL SELF-TEST | 13 |
| IN-CAR MONITOR | 13 |
| LED STATUS INDICATORS | .14 |
| CALIBRATION | 14 |
| TRAILS SAFE OPERATIONAL USE WITHOUT SWAYCONTROL | 15 |
| TRAILS SAFE+ OPERATIONAL USE WITH SWAYCONTROL | 16 |
| SERVICING | .18 |
| FAQS AND TROUBLESHOOTING | .18 |
| SPECIFICATIONS | .20 |
| WARRANTY TERMS AND CONDITIONS | .22 |

ABOUT THE TRAILS SAFE

The TrailSafe is a system designed to activate the electric brakes of a trailer or caravan (or similar) in the event of a disconnection from the towing vehicle. It utilises the house battery located on the trailer to activate the electric brake system and brake lights on the trailer in an emergency breakaway situation.

The TrailSafe also provides an indication of the charge status of the house battery and checks the condition of the pull pin and effective activation of the brakes. This information is displayed via a multi-coloured LED on the TrailSafe unit. This can also be displayed on the Bluetooth TrailCheck available for in-car monitoring if installed.

The mechanical pull pin is forcibly detached if the towing vehicle becomes separated from the trailer. Upon disconnection, the brakes and brake lights are activated as long as charge remains in the trailer battery or until the pin is replaced.

There are two available models in the TrailSafe series: the TrailSafe and TrailSafe+. The TrailSafe+ includes an extra cable to integrate it with BMAPRO's SwayControl.

KEY FEATURES

- ▣ Bluetooth and wired connectivity options for in-vehicle monitors.
- ▣ Works off house battery – no additional battery required.
- ▣ LED status indicators for full system safety check at trailer tongue.
- ▣ Tests pull pin functionality as well as battery health.
- ▣ Activates brake lights as well as electric brakes in the event of a breakaway.
- ▣ When wired to BMAPRO's proactive electronic stability control SwayControl and used with the wireless in-car monitor, provides comprehensive data on the RV safety system (only available with TrailSafe+).
- ▣ Meets Australian regulations for break away systems on trailers over 2000kg.

VEHICLE STANDARDS

Australian Design Rule 38/05 mandates that for all trailers having a Gross Trailer Mass over 2000 kg, an emergency braking system is required on all wheels and must be capable of automatically activating should the trailer become detached from the tow vehicle. In such a situation the brakes must remain active for a minimum of 15 minutes.

INSTALLATION INSTRUCTIONS

It is recommended that installation of the TrailSafe or TrailSafe+ is carried out by a trained auto electrician.

Using the supplied mounting screw, mount the unit on the right-hand side of the trailer's drawbar, about 300mm from the tow ball hitch.

The TrailSafe needs to be secured tightly to prevent it from vibrating loose. Tighten the mounting screw to between 10-25Nm.

WARNING

Do not tighten the mounting screw to a torque higher than 30Nm.

The unit must be mounted horizontally on top or the side of the drawbar, with the wires pointing towards the rear of the trailer (away from the tow vehicle) and the pull pin facing the tow vehicle.

Only one mounting point is required for the unit to swivel in an emergency.

Attach the other end of the pull pin cord to the towing vehicle using a D-shackle or similar.

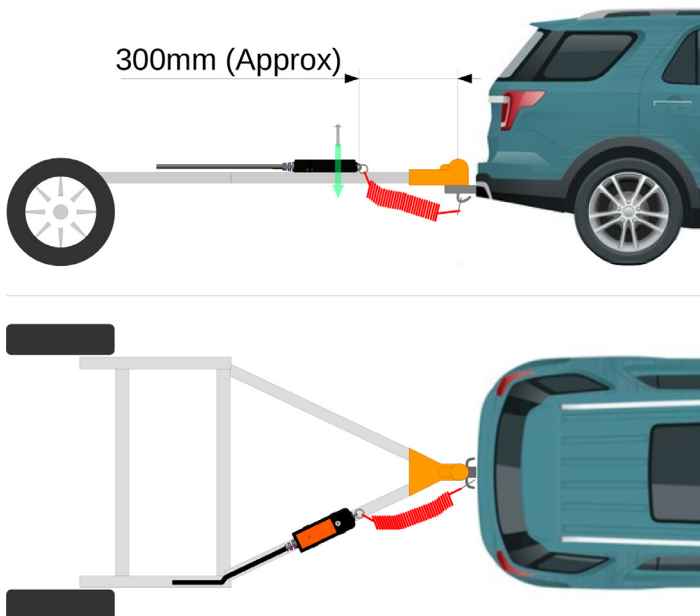

TRAILS SAFE WIRING INSTRUCTIONS

This section applies to the TrailSafe without the use of a SwayControl. If you are using the TrailSafe+ with the SwayControl, refer to the **TrailSafe+ with SwayControl Wiring Instructions** section.

The TrailSafe has multiple coloured wires coming from the rear side which require connection to ensure correct functionality. As this is a safety critical system, all wiring should be done by a suitably qualified Auto Electrician.

Wire the TrailSafe to the house battery, trailer brakes and brake lights. Refer to the **TrailSafe Wiring Diagram**.

| WIRE | CONNECTION |
|--|---|
| RED (14AWG / 2.5mm ²) | Connect to the positive of the brake lights. |
| BLUE (12 AWG/ 4mm ²) | Connect to the positive of the brakes. |
| PURPLE (14 AWG/ 2.5mm ²) | Connect to a remote voltage monitor. |
| WHITE (14 AWG/ 2.5mm ²) | Connect to the negative of the house battery. |
| BLACK/RED (12AWG / 4mm ²) | Connect to the positive of the house battery (30A fuse required). |
| GREEN (20AWG / 0.5mm ²) | If using LiFePO ₄ : connect to the positive terminal of the house battery. If using lead-acid: connect to the negative terminal of the house battery. |

Larger wire sizes may be used. The minimum is shown.

WARNING

The green wire must be connected to a battery positive terminal when a LiFePO₄ battery is used. Failure to do so may result in false battery capacity information.

For the black/red wire, a 30A automotive-grade fuse must be located as close to the trailer battery as possible, but not before the battery charging source feed.

WARNING

Failure to install the fuse may result in permanent and serious failure or damage to the TrailSafe and/or the wiring.

TRAILS SAFE WIRING DIAGRAM



Tow Vehicle

LEGEND

- 30A Fuse
- BatteryPlus35 (if installed)

| | | |
|----|---|--------------------|
| 8 | 1 | Pin 3/10: 0V |
| 9 | 6 | Pin 6: Brake Light |
| 10 | 5 | Pin 5: Brake |
| 11 | 3 | 3rd Party Monitor* |
| 12 | 2 | |
| | 7 | |
| | 4 | |



Trailer

TrailSafe

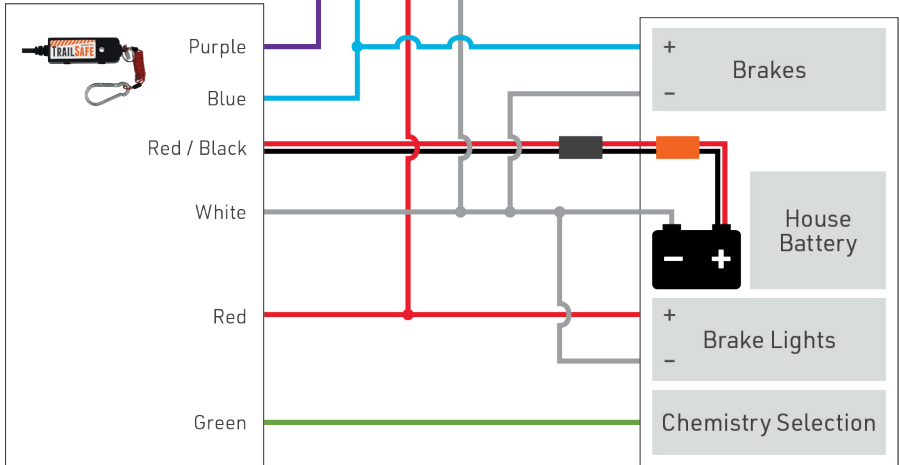

*Refer to your display monitor's manual for connection instructions.



 **WARNING**

If you have a BMPRO power management system installed, all negatives must pass through the power management system before connecting to the house battery.

 **WARNING**

If you have a BC300 installed, all negatives must pass through the power management system, and then the BC300 before connecting to the house battery.

The return (negative) wires of the brakes and brake lights from trailer must be wired directly to:

-  One of the negative output connections on the BMPRO power management system (if fitted)
-  To the non-battery side of a negative side shunt such as the BC300
-  Directly to the battery negative in all other cases

Ensure the house battery has a suitable charging source such as a BMPRO power management system or other charging means and is functioning correctly. Refer to manufacturer's instructions for these products as required. A basic charging means such as diode from the Auxiliary to the house battery may be employed in simple systems.

An external automotive-grade fuse is required to be fitted (30A maximum) between the TrailSafe and the battery to protect against wiring faults and issues.

TRAILS SAFE+ WITH SWAYCONTROL WIRING INSTRUCTIONS

This section applies to the TrailSafe+ when also using a SwayControl. If you are using the TrailSafe without a SwayControl, refer to the **TrailSafe Wiring Instructions** section.

The TrailSafe+ has multiple colored wires coming from the rear side which require connection to ensure correct functionality. As this is a safety critical system, all wiring should be done by a suitably qualified Auto Electrician.

Wire the TrailSafe+ to the house battery, trailer brakes and brake lights. Refer to the **TrailSafe+ With SwayControl Wiring Diagram**.

| WIRE | CONNECTION |
|---|--|
| RED (14AWG / 2.5mm ²) | Connect to the positive of the brake lights. |
| BLUE (12 AWG/ 4 mm ²) | Connect to the positive of the brakes. |
| PURPLE (14 AWG/ 2.5 mm ²) | Connect to a remote voltage monitor. |
| WHITE (14 AWG/ 2.5 mm ²) | Connect to the negative of the house battery. |
| BLACK/RED (12AWG / 4mm ²) | Connect to the positive of the house battery (30A fuse required). |
| GREEN (20AWG / 0.5mm ²) | If using LiFePO4 Unconnected: connect to the positive terminal of the house battery. If using lead-acid: connect to the negative terminal of the house battery. |
| YELLOW (20AWG / 0.5mm ²) | If SwayControl is being used, connect to the YELLOW cable of SwayControl via connector. If SwayControl is not being used, leave unconnected. |
| THIN RED (20AWG / 0.5mm ²) | If SwayControl is being used, to the RED cable of SwayControl via connector. If SwayControl is not being used, leave unconnected. |

Larger wire sizes may be used. The minimum is shown.

 **WARNING**

The green wire must be connected to a battery positive terminal when a LiFePO₄ battery is used. Failure to do so may result in false battery capacity information.

For the black/red wire, a 30A automotive-grade fuse must be located as close to the trailer battery as possible, but not before the battery charging source feed.

 **WARNING**

Failure to install the fuse may result in permanent and serious failure or damage to the TrailSafe and/or the wiring.

TRAILS SAFE+ WITH SWAYCONTROL WIRING DIAGRAM



Tow Vehicle

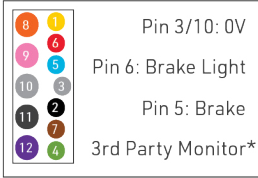

LEGEND

- 30A Fuse
- TrailSafe+ LED Connector
- SwayControl LED Connector

TrailSafe+

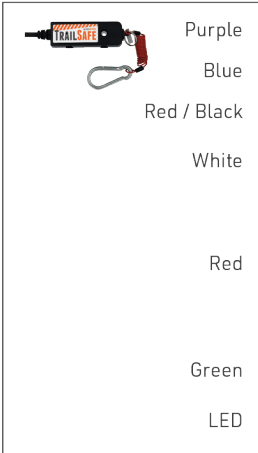

Trailer

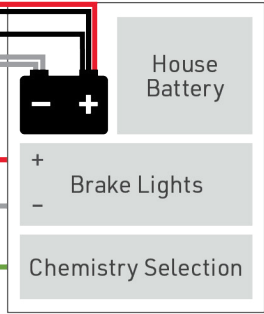

SwayControl



*Refer to your display monitor's manual for connection instructions.

 **WARNING**

Do not connect the TrailSafe+ blue wire directly to trailer brakes if the SwayControl is also installed. Failure to do so disables the unit's ability to control sway.



 **WARNING**

If you have a BMPRO power management system installed, all negatives must pass through the power management system before connecting to the house battery.

 **WARNING**

If you have a BC300 installed, all negatives must pass through the power management system, and then the BC300 before connecting to the house battery.

The return (negative) wires of the brakes and brake lights from trailer must be wired directly to:

-  One of the negative output connections on the BMPRO power management system (if fitted)
-  To the non-battery side of a negative side shunt such as the BC300
-  Directly to the battery negative in all other cases

Ensure the house battery has a suitable charging source such as a BMPRO power management system or other charging means and is functioning correctly. Refer to the manufacturer's instructions for these products as required. A basic charging means such as diode from the auxiliary to the house battery may be employed in simple systems.

An external automotive-grade fuse is required to be fitted (30A maximum) between the TrailSafe / TrailSafe+ and the battery to protect against wiring faults and issues.

USING THE TRAILS SAFE

INITIAL SELF-TEST





1. Before starting, ensure the TrailSafe or TrailSafe+ pull pin is in place.
2. Power up the TrailSafe or TrailSafe+ from your 12V battery as per the wiring instructions. The LED will display a continuous flashing **PURPLE**, indicating the first stage of calibration is in progress. This will last for up to 5 minutes.
3. When the first stage is completed, the LED will display a solid **PURPLE**. When this happens, pull the safety pin out. The LED will display a continuous flashing **PURPLE** again, indicating the second stage of calibration is in progress. This will last for up to 1 minute.
4. If the LED indicates an alternating **PURPLE/RED**, the wiring Voltage Drop in the black/red wire (+v) and/or the white wire (-v) is exceeding 10% of the nominal voltage. Check the wiring connections and consider increasing the black/red and/or the white wire size.
5. Once completed, LED will display a solid **PURPLE** again. At this stage, put the pull pin back in. The LED will then display a status indicator. For details, refer to the **LED Status Indicators** section of this manual.

IN-CAR MONITOR









If an in-car monitor is used, it needs to be located in a position where it is visible to the driver.

If you are using BMPRO's TrailCheck, refer to the **Wireless Monitor TrailCheck manual** for more details.

LED STATUS INDICATORS

| LED STATUS KEY | | | |
|---|----------------------|---|--------------|
|  | Continuous Flash |  | Solid Colour |
|  | Blink Every Few Secs |  | No Light |



CALIBRATION









| STATE | STATUS | CONDITION | SOLUTION |
|---------------------------|---|---|--|
| Initialisation pin in |  | The TrailSafe is in calibration. | Wait about 5 minutes until the LED displays a solid PURPLE . |
| |  | Completed 1st calibration stage. | Remove the pin. |
| Initialisation pin out |  | The pull pin is out when calibration starts. | Put the pull pin back in and wait for 1 minute, or power cycle the unit to restart calibration. |
| |  | The TrailSafe is in calibration. | Wait about 1 minute until the LED displays a solid PURPLE . |
| |  | Completed 2nd calibration stage. | Put the pin back in. |
| |  | The wiring voltage drop is exceeding 10% of the nominal voltage. The LED will flash both purple and red. | Check wiring and connections and consider increasing the wire size. |
| Initialisation pin out |  | The pull pin was removed before the calibration stage was completed. The LED will flash both purple and orange. | Put the pull pin back in to restart. |
| |  | The TrailSafe has finished calibrating, and is calculating battery capacity. | Wait for the LED to move to standby mode. The LED may stay orange for some time, or may move to standby mode very quickly. |

TRAILS SAFE OPERATIONAL USE WITHOUT SWAYCONTROL

If you are using the TrailSafe+ alongside BM PRO's SwayControl, refer to the **TrailSafe+ Operational Use With SwayControl** section of this manual.

Once the TrailSafe has finished calibrating and is ready for operational use, the colour of the LED will change depending on the charge state of the battery.









| COLOUR | CONDITION |
|---|--|
|  | The house battery capacity is sufficient for 15 minutes of emergency braking operation. |
|  | The house battery may have insufficient capacity for 15 minutes of emergency braking operation. Check the battery to ensure at least 10Ah of house battery capacity is available. |
|  | The house battery is not detected or there is insufficient capacity for 15 minutes of emergency braking operation. Charge or replace the house battery. |

| STATE | STATUS | CONDITION | SOLUTION |
|-----------------------|---|---|--|
| Standby mode |  | The TrailSafe is in standby as no brake activity has been detected for 1 minute. The colour will change depending on the charge state of the battery. | |
| Brake pedal depressed |  For 1 minute | The colour will change depending on the charge state of the battery. | |
| Pin out |  | A trailer breakaway has occurred. The colour will change depending on the charge state of the battery. | |
| |  | There is a TrailSafe breakaway switch fault. The LED will flash both orange and red. | Do not use unit. Replace the unit. |
| Battery flat |  Always on | The battery is flat. | Charge or replace the house battery. |
| Other |  | The TrailSafe is in standby, or there is no power, or the voltage is less than: <ul style="list-style-type: none">  10.5V for lead-acid batteries  11.5V for Lithium batteries | If necessary, check the TrailSafe by depressing the brake. |







TRAILS SAFE+ OPERATIONAL USE WITH SWAYCONTROL





If you are using the TrailSafe+ without BMAPRO's SwayControl, refer to the **TrailSafe Operational Use Without SwayControl** section of this manual.

The LED on the TrailSafe+ displays different indicators if used with BMAPRO's SwayControl.

| STATE | STATUS | CONDITION | SOLUTION |
|--------------------------------------|--|--|--|
| Battery flat |  Always on | The battery is flat. ⚠ Warning: This state will override other LED indicators. Refer to the Battery Flat section for more information. | Charge or replace the house battery |
| Normal operation, battery sufficient |  | | |
| Sway event active |  | | |
| Standby mode |  | The TrailSafe is in standby as no brake activity has been detected for 1 minute, and the SwayControl is in "sleep" mode | |
| Battery insufficient |  | The house battery may have insufficient capacity for 15 minutes of emergency braking operation. | Check the battery to ensure at least 10Ah of house battery capacity is available |
| SwayControl not detected |  | The SwayControl is not detected by the TrailSafe+. | Check if the SwayControl is connected |
| No power |  | No power to SwayControl after a "wake-up" signal from the brake controller. | Check the quality of power, ground and brake controller wire connections. Check for any blown fuses on the tow vehicle and trailer |
| Battery over-voltage / under-voltage |  | There is a house battery overvoltage (> 20V) or undervoltage (< 3V) on the SwayControl. | Check the power source voltage. The required voltage is 12-15V |

LED STATUS KEY







| | | | |
|---|------------------------------|---|------------------------------|
|  | Continuous Flash |  | Solid Colour |
|  | Blink Once Every 10 Secs |  | No Light |
|  | Blink Once Every Few Secs |  | Blink Twice Every Few Secs |
|  | Blink 3 Times Every Few Secs |  | Blink 4 Times Every Few Secs |

| STATE | STATUS | CONDITION | SOLUTION |
|---------------|---|---|---|
| Off-road mode |  | The SwayControl is disabled momentarily. The unit will return to normal operation when not on rough terrain. The LED will flash both green and red. | |
| Other |  | The three following conditions are met: <ul style="list-style-type: none">  The SwayControl is in "sleep" mode.  The TrailSafe+ is in standby.  The house battery capacity is sufficient for 15 minutes of emergency braking operation. | If necessary, check the TrailSafe by depressing the brake |
| | | There is no power. | |

Battery Flat

If the battery is flat, the LED will show a constant **RED**, regardless of any other condition except fault indicators.

Fault Indicators

| STATE | STATUS | CONDITION | SOLUTION |
|--------------------|--|--|---|
| System malfunction |  Always on | Either: <ul style="list-style-type: none">  The battery is flat.  The SwayControl has suffered a system malfunction. | Charge the battery. If the battery is not flat, a service centre repair is required |
| |  | The SwayControl has suffered a system malfunction. | A service centre repair is required |
| |  | The SwayControl has no control of the trailer. | A service centre repair is required |
| Left brake short |  | There is a wiring short in the left-side brake. | Repair the wiring short |
| Right brake short |  | There is a wiring short in the right-side brake. | Repair the wiring short |

If a service centre repair is required, please contact your authorised BPRO SwayControl Authorised Repair Centre.

SERVICING

Do not attempt to service the TrailSafe or TrailSafe+ yourself, or dismantle, modify or repair the TrailSafe or TrailSafe+ yourself, as this will void your warranty. If your TrailSafe product requires servicing, please consult your BMPRO dealer or visit teambmpro.com for assistance.

FAQS AND TROUBLESHOOTING

Need more help troubleshooting your TrailSafe or TrailSafe+?

Contact our customer service team online at teambmpro.com/technical-support.

When I pull the pin, the TrailSafe indicator does not illuminate?

1. Check the supplied fuse on the black/red wire.
2. Check the wiring matches the diagram.
3. Ensure TrailSafe or TrailSafe+ pin slot is clean of dirt.
4. Ensure the house battery is charged.

Why should I test TrailSafe before hitching it to the tow vehicle?

Testing the TrailSafe or TrailSafe+ ensures that the house battery has sufficient capacity to operate the brakes for at least 15 minutes should the need arise.

What is the difference between a solid green, orange and red status indicators on the TrailSafe?

GREEN confirms that the battery has been detected, has been determined to have sufficient charge and no fault in the wiring to the brakes has been detected. Good to go!

ORANGE indicates there is a need for a secondary check as the battery maybe too low.

RED indicates that battery not detected or not having enough capacity for 15 minutes emergency brake operation.

It is possible that with dual axles brakes, heavy brake light loads, warm batteries, a large load on the trailer etc, that the battery is sufficient but failing to give a clear pass.

It is necessary that there is at least 10Ah of useful battery capacity remaining, which may require 20% of aged 100Ah-rated battery for this load. If any loads (e.g. lights, 12V fridges) are on in the trailer, turn these off if possible. If your trailer or caravan has a display showing remaining battery capacity this should be able to provide a useful indication that there is enough battery capacity remaining for the emergency braking function.

Refer to the **LED Status Indicators** section of this manual for information.

Can I use a wired in-car monitor?

A wired 12VDC battery voltage indicator can be used with the TrailSafe or TrailSafe+ if desired.

When I pull the pin, the LED display is flashing RED and ORANGE?

The pull pin is faulty, which may cause the brakes to not operate correctly or for as long as desired.

Refer to the **LED Status Indicators** section of this manual for information.

I have charged my house battery, but the TrailSafe shows a RED LED.

If a large load is applied to the house battery, such as a fridge, the house battery terminal voltage may drop below the minimum TrailSafe threshold, due to the internal resistance of the house battery.

Switch off any loads and re-test.

Refer to the **LED Status Indicators** section of this manual for information.

I thought it was not a good idea to remove the pin?

This is a key feature of the device. By removing the pin to test the unit, it checks to ensure that the switch is functioning. It also checks the battery is ready to function should an emergency happen.

The LED is indicating a solid RED all the time?

The battery voltage is very low and is considered flat. Charge or replace the battery.

Refer to the **LED Status Indicators** section of this manual for information.

SPECIFICATIONS

| TrailSafe / TrailSafe+ | |
|---------------------------------|--|
| System Voltage | 12V Nominal (not suitable for 24V systems) |
| Electric Brake Load | 18A max |
| Brake Light Load | 8A max |
| Communications | Bluetooth Low Energy (BLE 5.0) |
| Wired Monitor Current | 30mA max |
| Battery Chemistry Compatibility | LiFePO4 / Lead-acid |
| Temperature | -20°C to 60°C |
| IP Rating | IP67 |
| Battery Nominal Capacity | 70Ah - 300Ah |

WARRANTY TERMS AND CONDITIONS

Our goods come with guarantees that cannot be excluded under the Australian Consumer Law. You are entitled to a replacement or refund for a major failure and for compensation for any other reasonably foreseeable loss or damage. You are also entitled to have the goods repaired or replaced if the goods fail to be of acceptable quality and the failure does not amount to a major failure.

This warranty is provided by SETEC BMPRO Pty Ltd (ABN) ("BMPRO") for its products. Warranty benefits are applied along with any rights and remedies required by Australian State and Federal legislation that cannot be excluded. No part of this warranty excludes, restricts or modifies any State or Federal legislation relating to the supply of goods and services which cannot be excluded, restricted or modified.

WARRANTY

BMPRO warrants that the product will be free from any faults in materials and workmanship beginning from the original date of purchase under standard application, installation, use and service conditions, subject to the exclusions and limitations detailed below. The warranty period of the product is two years.

If, before the warranty period has ended, a fault occurs with the product and BMPRO finds the product is defective in materials or workmanship, BMPRO at its discretion will subject to further rights accorded by the Australian Consumer Law to either:

- Repair the defective product
- Replace the defective product
- Provide a refund to the purchaser for the price paid at purchase for the defective product.

WARRANTY CLAIMS

Refer to your manual before using the product. Most BMPRO products are designed to be installed by a suitably qualified installer. The products should be carefully inspected by you or your installer before installation for any visible manufacturing faults. If a product has been installed incorrectly, BMPRO accepts no responsibility on top of our consumer guarantee obligations.

1. If a fault covered by warranty occurs, the purchaser must either contact the dealer where the product was purchased within 7 days, or BMPRO at the contact details listed.
2. All warranty claims must include: (a) proof of purchase of the product; (b) complete details of the alleged fault; (c) any relevant documentation related to the fault (such as photographs or maintenance records); (d) return material authorisation (RMA) number.
3. The product must be made available to BMPRO or its authorised installer for inspection and testing within 14 days of contacting BMPRO or the dealer.
4. The reasonable cost of delivery and installation of any products or components of products that have been repaired or replaced to the place of purchase notified to BMPRO is covered by the warranty provided by BMPRO, along with the reasonable costs of removal and return of any products determined by BMPRO to be defective.
5. If, on return to BMPRO or on investigation by BMPRO, inspection and testing determines there is no fault in the product, the purchaser must pay BMPRO's reasonable costs of testing and investigating the product, as well as transportation and shipping costs.

REGISTER A WARRANTY OR REPAIR WITH BMPRO

To register a warranty or repair with BMPRO:

1. Lodge a support request via teambmp.com/technical-support or email customerservice@teambmp.com
2. If agreed with the BMPRO Product Specialist team, register a warranty claim or repair via teambmp.com/warranty-claim or email customerservice@teambmp.com to obtain a Return Material Authorisation (RMA) number.
3. Package and send the product to:

BMPRO Warranty Department
19 Henderson Road
Knoxfield, VIC 3180

Please mark RMA details on the outside of the packaging.

4. Ensure your package also includes a copy of the proof of purchase, a complete description of the fault and your contact details including phone number and return address.

EXCLUSIONS

This warranty will not be applicable where: (a) the product has been altered, modified or repaired by someone other than BMPRO, an authorised installer or a qualified auto electrician; (b) the product has not been installed properly by either the user or manufacturer; (c) BMPRO cannot establish a fault in the product after inspection and testing; (d) the product has been used for purposes other than that for which it was designed; (e) the fault in the product has occurred due to a failure by the purchaser to ensure proper use and maintenance of the product according to BMPRO's instructions, recommendations and specifications (including maintenance); (f) the product has been subjected to abnormal conditions, such as environmental, temperature, water, fire, humidity, pressure, stress or similar; (g) the fault has been caused by abuse, misuse, neglect or accident; (h) the fault has been caused by a power surge or other kind of fault in the supply of electricity; (i) unauthorised parts or accessories have been used on or in relation to the product; (j) the appearance of the Product has deteriorated; or (k) the fault is a result of common wear & tear.

LIMITATIONS

No express warranties or representations are made by BMPRO other than what is set out in this warranty. The absolute limit of BMPRO's liability under this express warranty is the repair or replacement of the product or part of the product.

CONTACT

BMPRO's contact details for warranty claims are:

SETEC BMPRO Pty Ltd
19 Henderson Road,
Knoxfield, VIC 3180
Phone: (03) 9763 0962
Email: customerservice@teambmp.com

Warranty Claim and Product Repair Form:
<https://teambmp.com/warranty-claim/>

Registering your BMPRO product is an important step to ensure that you receive all the benefits you are entitled to.

Please complete the online registration form at <https://teambmp.com/product-registration/> for your new product today.

POWERING YOUR ADVENTURES.



**TEAM
BM PRO
.COM**

BM PRO

customerservice@teambmpro.com

19 Henderson Rd, Knoxfield VIC 3180 Australia

teambmpro.com