



Yuasa NP Series VRLA Battery, 5 Years Design Life

The Yuasa NP series is a high energy density Valve Regulated Lead Acid (VRLA) battery that uses advanced plate technology and sealed construction. Its unique sealing technique prevents electrolyte leakage when the battery is mounted either horizontally or vertically. Manufactured in Yuasa quality assured factories, the Yuasa NP series offers absolute reliability and minimal maintenance for end users.

- Sealed construction with pressure relief system
- Operation in any orientation (except in an inverted position)
- Heavy duty grids
- Low self discharge
- Wide operating temperature range (-15°C to +50°C)
- Recyclable materials used in battery

General Performance

Battery	NP7.2-12FR	
Application	Floating	
Design Life	5 Years	
Nominal Capacity	7.2Ah	
Actual Capacity at 25°C	1 hour rate to 1.60Vpc	4.50Ah
	5 hour rate to 1.70Vpc	6.20Ah
	10 hour rate to 1.75Vpc	6.54Ah
	20 hour rate to 1.75Vpc	7.2Ah



Electrolyte

Fully charge density at 25°C	1.300
Density Range	1.290-1.310
Gelled/Absorbed	Absorbed
Mounting Orientation	Vertical/Horizontal

Plates

<b>Positive Plates:</b>	
Number/cell	3
Type	Flat
Material of grid	Lead-Calcium-Tin Alloy
Thickness	3.5mm
<b>Negative Plates:</b>	
Number/cell	4
Type	Flat
Material of grid	Lead-Calcium-Tin Alloy
Thickness	2mm

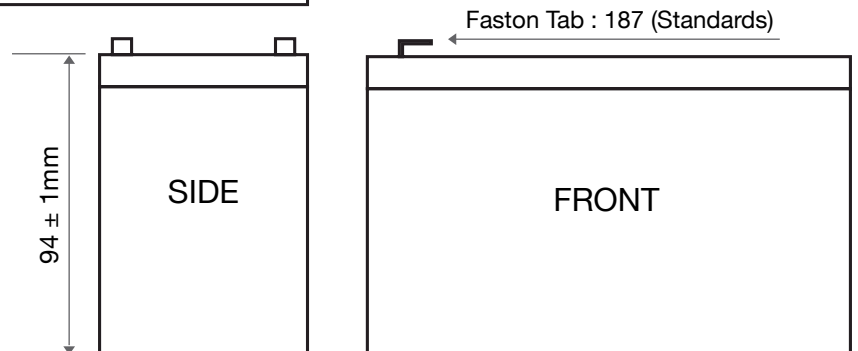
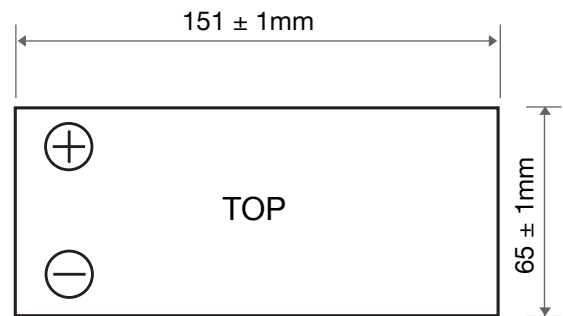



Yuasa NP Series VRLA Battery, 5 Years Design Life

**Physical Properties**

Separators	
Type	Glass Mat
Is glass fibre included?	Yes
Container & Cover Materials	
Lid Material, Colour	Acrylonitrile Butadiene Styrene ABS / Black
Container Material, Colour	Acrylonitrile Butadiene Styrene ABS / Grey
Flame Retardant	Yes
Safety Vent Operational Pressure	20kPa
Dimensions:	
Overall Width	151mm
Depth	65mm
Height	94mm
Overall Height	97.5mm
Battery Weight (kg)	
Total Weight (wet)	2.65kg

**Electrical Properties**

Self Discharge Rate @ 20°C	<3% per month		
Normal Charge (Amperes)	0.72A		
Max. Charge (Amperes)	1.80A		
Internal Resistance (mOHMS)	25 m Ω		
Volts End of Charge	2.260Vpc @ 25		
	20°C	25°C	30°C
Float Voltage (Vpc)	2.275Vpc	2.260Vpc	2.245Vpc
Float Current (mA)	<7mA	<7mA	<7mA
Initial Short circuit current (A)	500		
Efficiency at 10 hour rate (%):			
Ampere-Hour	>90%		
Watt-Hour	>80%		

**Compliant Standard**

Battery Standard	JIS C8702
------------------	-----------

**Discharge Characteristic Curves: NP Batteries**

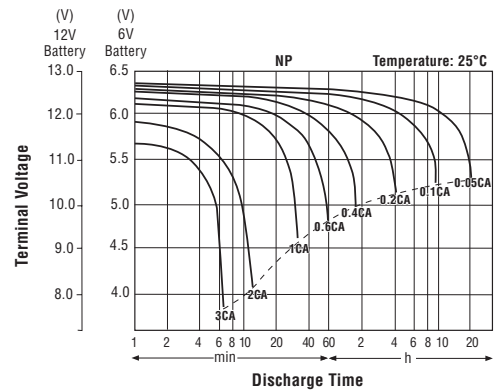

**Self Discharge Characteristics**

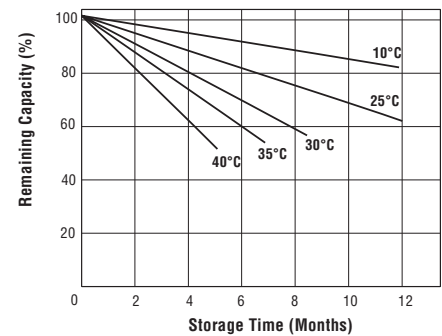

**Temperature Effects in Relation to Battery Capacity**

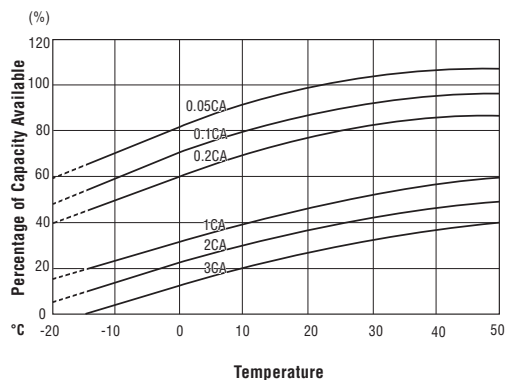

An affiliated business of the GS Yuasa Corporation, Century Yuasa has an 80-year history of supplying a range of stored energy solutions to the Australian market. An established network of sales and distributions offices throughout Australia and New Zealand has seen the business gain the trust and respect from its customers by focusing on quality products and exceptional customer service. CenturyYuasa is Australia's enduring manufacturer of stored energy products.