



OWNER'S MANUAL

# MINI BOOST



TEAMBMPRO.COM

# SAFETY PRECAUTIONS

Please read the Safety Precautions before installing or using the MiniBoost. Be sure to observe all precautions without fail. Failure to observe these instructions properly may result in property damage, or personal injury which depending on the circumstances may be serious and cause loss of life.

## WARNING



Correct installation is the most critical factor in ensuring the safe use of the MiniBoost. If every consideration of these instructions has been satisfied, the MiniBoost will be safe to operate.



Batteries are electrically live and must be treated with extreme caution. They can supply high short circuit currents, even if they appear damaged or undamaged.



Do not allow water or other liquids to enter the power supply area.



Contact with water will cause the device to short-circuit or corrode.



Do not use this product in environments that are excessively hot, cold, dusty or humid or where it will be exposed to magnetic fields or long periods of sunshine. Such exposure may cause the product or your battery to fail, catch fire or explode.



Clean the housing of this product lightly with a dry or moist cotton cloth. Do not use alcohol, thinners, benzene or any other chemical cleaner.



The MiniBoost is a high precision electronic product. It contains no user-serviceable parts inside. Do not try to dismantle, modify or repair it yourself. Disassembly, service or repair by an unauthorised person will void the warranty.



Copyright © 2024

REV 7.0

Designed by BM PRO, one of Australia's leading power solution experts, the BM PRO product range is proudly designed and manufactured in Melbourne, Australia, and represent a high-quality product that will provide years of service.

**DISCLAIMER:** BM PRO accepts no liability for any loss or damage which may occur from the improper or unsafe use of its products. Warranty is only valid if the unit has not been modified or misused by the customer.

# CONTENTS

|  |           |
|--|-----------|
| <b>SAFETY PRECAUTIONS</b> . . . . .                          | <b>2</b>  |
| <b>ABOUT THE MINIBOOST</b> . . . . .                         | <b>4</b>  |
| <b>INSTALLING THE MINIBOOST</b> . . . . .                    | <b>5</b>  |
| <b>WIRING THE MINIBOOST</b> . . . . .                        | <b>6</b>  |
| WIRE SIZE . . . . .  | 6         |
| FUSING . . . . .   | 6         |
| WIRING THE MINIBOOST TO THE BATTERYPLUS35 . . . . .          | 7         |
| WIRING THE MINIBOOST TO THE J35 . . . . .                    | 8         |
| <b>SERVICING</b> . . . . .                                   | <b>9</b>  |
| <b>FAQS AND TROUBLESHOOTING</b> . . . . .                    | <b>10</b> |
| <b>SPECIFICATIONS</b> . . . . .                              | <b>11</b> |
| <b>WARRANTY TERMS AND CONDITIONS</b> . . . . .               | <b>12</b> |
| <b>LIMITED WARRANTY TERMS AND CONDITIONS (USA)</b> . . . . . | <b>14</b> |
| <b>COMPLIANCE</b> . . . . .                                  | <b>15</b> |

# ABOUT THE MINIBOOST

The MiniBoost is a compact DC-DC battery charger designed to provide effective charging of a caravan/camper house battery from the towing vehicle's electrical system, even if the voltage delivered from the towing vehicle is lower than that normally required to charge the house battery.

The MiniBoost is designed to work with BMPRO's BatteryPlus35, J35 and ASPero power management systems.

When the MiniBoost is receiving sufficient input voltage, the input fuse is illuminated with a green LED light.

The MiniBoost is not a power supply and must be connected to a battery. If the battery voltage is too low the MiniBoost will not connect.

The MiniBoost can be used to charge all types of lead acid batteries, and can charge lithium LiFePO<sub>4</sub> batteries if it is connected to a lithium-compatible BMPRO power management system that has solar connected.

If the MiniBoost is not connected to a lithium-compatible BMPRO power management system, it will charge LiFePO<sub>4</sub> batteries to around 90%. The output voltage of the MiniBoost is slightly lower than the LiFePO<sub>4</sub> optimal charging voltage required to achieve full charge.

# INSTALLING THE MINIBOOST

Installation of the MiniBoost should only be carried out by suitably qualified personnel.

The following items are required for the installation:

- ▣ 30A relay
- ▣ Wire connector
- ▣ In-line 30A fuse
- ▣ Trailer connector

The MiniBoost can be installed in any orientation. The MiniBoost should be installed in a well-ventilated area near the house battery in the caravan, with free air movement around it for optimal performance and reliability.

The MiniBoost should be securely mounted to a suitably strong surface. Dimensional details are provided below. The MiniBoost may be mounted in any orientation.

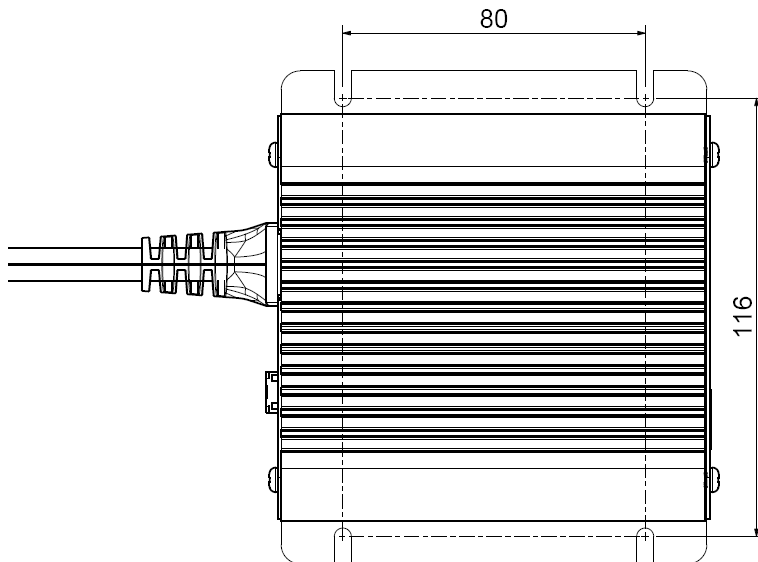

# WIRING THE MINIBOOST

It is recommended that the MiniBoost connect to the vehicle through a minimum 30A isolating relay and a minimum 30A fuse.

Connecting through a relay prevents the vehicle battery from discharging when the vehicle is not in use.

The MiniBoost has four connections. To connect the MiniBoost:

1. Connect the orange wire to the batt+ input.
2. Connect the white wire to the batt- input.
3. Connect the red wire to the batt+ of the battery to be charged.
4. Connect the black wire to the batt- of the battery to be charged.

## WIRE SIZE

Cables should be sized to carry 30A. The minimum recommended wire size is 5mm<sup>2</sup>.

The wiring resistance, including connectors, should be less than 100mR total (vehicle battery to MiniBoost input wires).

If the circuit resistance (including the fuse, relay and connectors) is too high, the performance of the MiniBoost may degrade.

## FUSING

Overcurrent protection is provided by a green mini-blade 30A automotive fuse.

If you need to replace the fuse, always use a fuse with the same type and rating.

# WIRING THE MINIBOOST TO THE BATTERYPLUS35

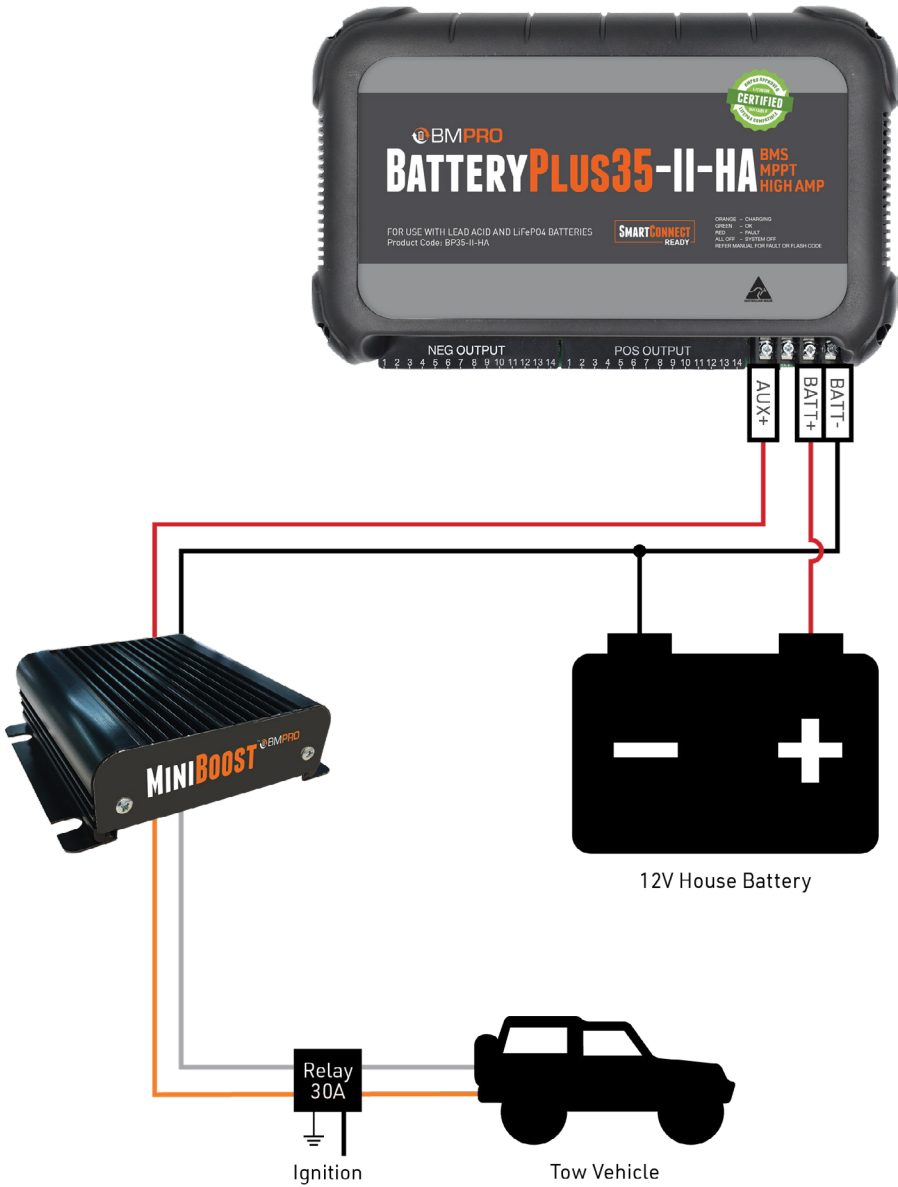

## WIRING THE MINIBOOST TO THE J35

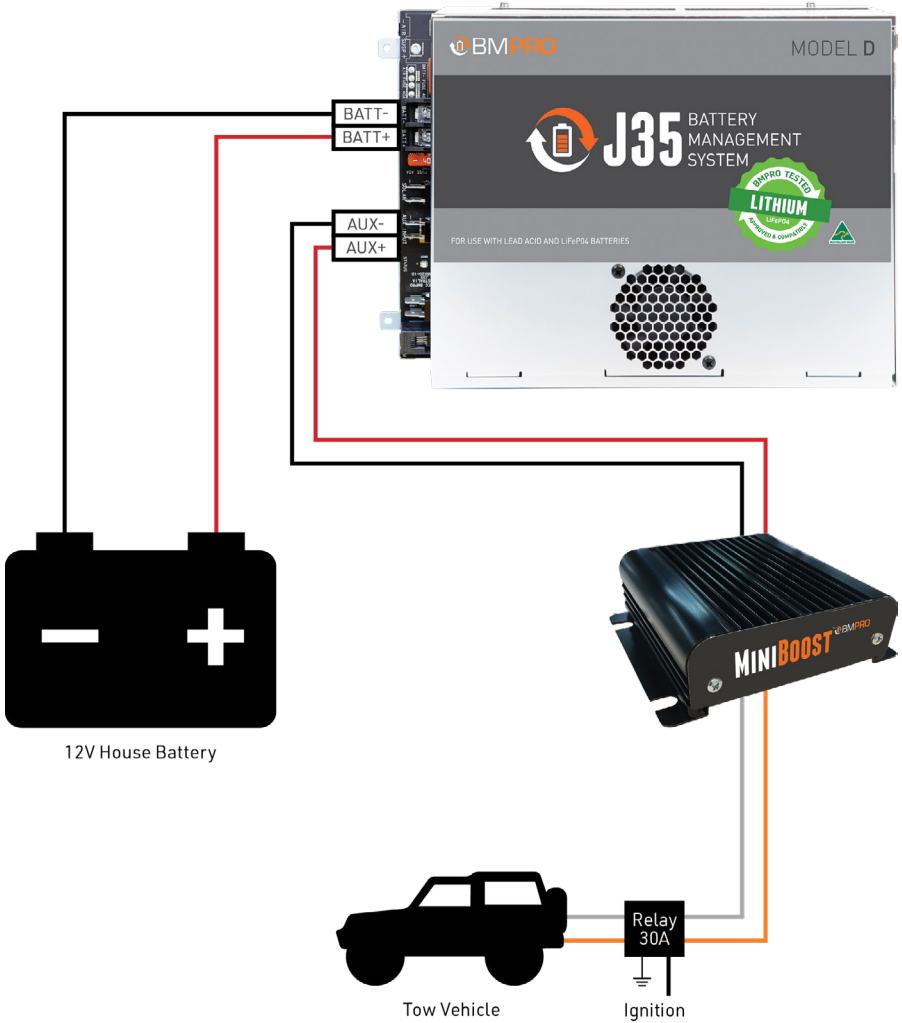



# SERVICING

Do not attempt to service the MiniBoost, OR dismantle, modify or repair the MiniBoost yourself; this will void your warranty. If your MiniBoost requires servicing, please consult your BMPRO dealer or visit [teambmpro.com](https://teambmpro.com) for assistance.

# FAQS AND TROUBLESHOOTING

## **Need help troubleshooting your MiniBoost?**

Contact our customer service team online at [teambmpro.com/technical-support](https://teambmpro.com/technical-support)

## **Can I use the MiniBoost if I don't have a BMPRO power management system?**

The MiniBoost can work on the auxiliary input of other power management systems, or it can be directly connected to a battery.

## **Will the MiniBoost work if I have several batteries installed in parallel?**

The MiniBoost is capable of charging multiple batteries installed in parallel.

## **Can I connect solar to the MiniBoost?**

The MiniBoost will not connect directly to solar.

## **What will happen if I install the MiniBoost without the relay?**

If the relay is not installed alongside the MiniBoost, and the vehicle remains connected, the vehicle battery will be drained, and the secondary battery may become overcharged.

# SPECIFICATIONS

| MINIBOOST                                |   |
|--|---|
| Input Voltage Range                      | 10V to 15V  |
| Output Current                           | Boost Mode: 20A<br>Bypass Mode: 30A                           |
| Output Voltage                           | Boost Mode: 14.4V<br>Bypass Mode: <1V less than input voltage |
| Output Ripple Voltage                    | <150mV  |
| Output Current Protection                | Boost Mode: 21A (electronic)<br>Bypass Mode: 31A (fuse)       |
| Start Voltage                            | 12.2V to 12.9V  |
| Disconnect Voltage                       | 9.1V to 10.5V   |
| Battery Drain (tow vehicle disconnected) | <20mA   |
| Efficiency                               | >80%  |
| Ambient                                  | 0°C to 50°C   |
| Standards                                | RCM Approval, EMC CISPR 11, CFR 47 FCC Part 15                |
| Weight                                   | 0.8kg   |

# WARRANTY TERMS AND CONDITIONS

Our goods come with guarantees that cannot be excluded under the Australian Consumer Law. You are entitled to a replacement or refund for a major failure and for compensation for any other reasonably foreseeable loss or damage. You are also entitled to have the goods repaired or replaced if the goods fail to be of acceptable quality and the failure does not amount to a major failure.

This warranty is provided by SETEC BMPRO Pty Ltd (ABN) ("BMPRO") for its products. Warranty benefits are applied along with any rights and remedies required by Australian State and Federal legislation that cannot be excluded. No part of this warranty excludes, restricts or modifies any State or Federal legislation relating to the supply of goods and services which cannot be excluded, restricted or modified.

## WARRANTY

BMPRO warrants that the product will be free from any faults in materials and workmanship beginning from the original date of purchase under standard application, installation, use and service conditions, subject to the exclusions and limitations detailed below. The warranty period of the product is two years.

If, before the warranty period has ended, a fault occurs with the product and BMPRO finds the product is defective in materials or workmanship, BMPRO at its discretion will subject to further rights accorded by the Australian Consumer Law to either:

- Repair the defective product
- Replace the defective product
- Provide a refund to the purchaser for the price paid at purchase for the defective product.

## WARRANTY CLAIMS

Refer to your manual before using the product. Most BMPRO products are designed to be installed by a suitably qualified installer. The products should be carefully inspected by you or your installer before installation for any visible manufacturing faults. If a product has been installed incorrectly, BMPRO accepts no responsibility on top of our consumer guarantee obligations.

1. If a fault covered by warranty occurs, the purchaser must either contact the dealer where the product was purchased within 7 days, or BMPRO at the contact details listed.
2. All warranty claims must include: (a) proof of purchase of the product; (b) complete details of the alleged fault; (c) any relevant documentation related to the fault (such as photographs or maintenance records); (d) return material authorisation (RMA) number.
3. The product must be made available to BMPRO or its authorised installer for inspection and testing within 14 days of contacting BMPRO or the dealer.
4. The reasonable cost of delivery and installation of any products or components of products that have been repaired or replaced to the place of purchase notified to BMPRO is covered by the warranty provided by BMPRO, along with the reasonable costs of removal and return of any products determined by BMPRO to be defective.
5. If, on return to BMPRO or on investigation by BMPRO, inspection and testing determines there is no fault in the product, the purchaser must pay BMPRO's reasonable costs of testing and investigating the product, as well as transportation and shipping costs.

## REGISTER A WARRANTY OR REPAIR WITH BMPRO

To register a warranty or repair with BMPRO:

1. Lodge a support request via [teambmp.com/technical-support](https://teambmp.com/technical-support) or email [customerservice@teambmp.com](mailto:customerservice@teambmp.com)
2. If agreed with the BMPRO Product Specialist team, register a warranty claim or repair via [teambmp.com/warranty-claim](https://teambmp.com/warranty-claim) or email [customerservice@teambmp.com](mailto:customerservice@teambmp.com) to obtain a Return Material Authorisation (RMA) number.
3. Package and send the product to:

BMPRO Warranty Department  
19 Henderson Road  
Knoxfield, VIC 3180

Please mark RMA details on the outside of the packaging.

4. Ensure your package also includes a copy of the proof of purchase, a complete description of the fault and your contact details including phone number and return address.

## EXCLUSIONS

This warranty will not be applicable where: (a) the product has been altered, modified or repaired by someone other than BMPRO, an authorised installer or a qualified auto electrician; (b) the product has not been installed properly by either the user or manufacturer; (c) BMPRO cannot establish a fault in the product after inspection and testing; (d) the product has been used for purposes other than that for which it was designed; (e) the fault in the product has occurred due to a failure by the purchaser to ensure proper use and maintenance of the product according to BMPRO's instructions, recommendations and specifications (including maintenance); (f) the product has been subjected to abnormal conditions, such as environmental, temperature, water, fire, humidity, pressure, stress or similar; (g) the fault has been caused by abuse, misuse, neglect or accident; (h) the fault has been caused by a power surge or other kind of fault in the supply of electricity; (i) unauthorised parts or accessories have been used on or in relation to the product; (j) the appearance of the Product has deteriorated; or (k) the fault is a result of common wear & tear.

## LIMITATIONS

No express warranties or representations are made by BMPRO other than what is set out in this warranty. The absolute limit of BMPRO's liability under this express warranty is the repair or replacement of the product or part of the product.

## CONTACT

BMPRO's contact details for warranty claims are:

SETEC BMPRO Pty Ltd  
19 Henderson Road,  
Knoxfield, VIC 3180  
Phone: (03) 9763 0962

Email: [customerservice@teambmp.com](mailto:customerservice@teambmp.com)

Warranty Claim and Product Repair Form:  
<https://teambmp.com/warranty-claim/>

Registering your BMPRO product is an important step to ensure that you receive all the benefits you are entitled to.

Please complete the online registration form at <https://teambmp.com/product-registration/> for your new product today.

# LIMITED WARRANTY TERMS AND CONDITIONS (USA)

Registering your BMPRO product is an important step to ensure that you receive all the benefits you are entitled to. Please visit [teambmp.com](http://teambmp.com) to complete the online registration form for your new product today.

## WHAT THIS LIMITED WARRANTY COVERS

This warranty covers any defect or malfunction in your BMPRO product. Under this warranty you are entitled to have such goods replaced, repaired or refunded.

## WHAT THIS LIMITED WARRANTY DOES NOT COVER

This warranty does not extend to product failures or defects caused by, or associated with, but not limited to:

- Failure to install or maintain correctly, unsuitable physical or operating environment, accident, acts of God, hazard, misuse, unauthorized repair, modification or alteration, natural disaster, corrosive environment, insect or vermin infestation and failure to comply with any additional instructions supplied with the product.
- BMPRO may seek reimbursement of any costs incurred when a product is found to be in proper working order or damaged as a result of any of the warranty exclusions listed above.
- BMPRO will not be liable for any costs, charges or expenses incurred in the process of returning a product to initiate a warranty claim.

## HOW LONG THE WARRANTY LASTS

BMPRO warrants products against defects for a period of two years, commencing from the original date of purchase.

## CLAIMS PROCESS

Proof of purchase is required before the product can be deemed to be within the warranty period.

To enquire or make a claim under this warranty, please follow these steps:

A. Prior to returning a BMPRO product, please email [service@teambmp.com](mailto:service@teambmp.com) to obtain a Return Material Authorisation (RMA) number.

B. Package and send the product to:

**BMPRO WARRANTY DEPARTMENT  
UNIT 1 821 E WINDSOR AVE  
ELKHART IN 46514**

Please mark RMA details on the outside of the packaging.

C. Please ensure the package also includes: a copy of the proof of purchase, a detailed description of the fault and your contact details including phone number and return address.

## HOW STATE LAW APPLIES

This warranty gives you specific legal rights, and you may also have other rights which vary from state to state.

# COMPLIANCE

This device complies with part 15 of the FCC Rules. Operation is subject to the following two conditions: (1) This device may not cause harmful interference, and (2) this device must accept any interference received, including interference that may cause undesired operation.

Note: This equipment has been tested and found to comply with the limits for a Class B digital device, pursuant to Part 15 of the FCC Rules. These limits are designed to provide reasonable protection against harmful interference in a residential installation. This equipment generates, uses and can radiate radio frequency energy and, if not installed and used in accordance with the instructions, may cause harmful interference to radio communications. However, there is no guarantee that interference will not occur in a particular installation. If this equipment does cause harmful interference to radio or television reception, which can be determined by turning the equipment off and on, the user is encouraged to try to correct the interference by one or more of the following measures:

- Reorient or relocate the receiving antenna,
- Increase the separation between the equipment and receiver,
- Connect the equipment into an outlet on a circuit different from that to which the receiver is connected,
- Consult the dealer or an experienced radio/TV technician for help.

Warning: Any changes or modifications not expressly approved by BMPRO could void the user's authority to operate this equipment.

**POWERING YOUR ADVENTURES.**



**BMPRO**

[customerservice@teambmpro.com](mailto:customerservice@teambmpro.com)

19 Henderson Rd, Knoxfield VIC 3180 Australia | Unit 1, 821 E Windsor Ave, Elkhart IN 46514 USA

[teambmpro.com](http://teambmpro.com)