



Drypower

12.8V	102.6Ah	LiFePO ₄	1313Wh
-------	---------	---------------------	--------

12LFP102SL

Rechargeable Lithium Iron Phosphate Battery

- HIGH CYCLE LIFE
- BUILT IN CIRCUIT PROTECTION
- SUPERIOR CHARGE / DISCHARGE EFFICIENCY
- LOWER TOTAL COST OF OWNERSHIP
- LONG SERVICE LIFE



SPECIFICATIONS

Nominal Voltage	12.8V
Nominal Capacity @5hr Rate	102.6Ah
Watt-hour	1313.28Wh
Dimensions	
Length	395 ± 3mm
Width	110 ± 3mm
Height	286.5 ± 3mm
Weight	13.1kg
Internal Resistance (at 1KHz)	≤60mΩ
Charge @25°C	
Standard Charge Current	20.52A
Maximum Charge Current	80A
Max Charge Voltage	14.6V
Discharge @25°C	
Standard Discharge Current	20.52A
Max. Continuous Discharge	80A
Cut-off Voltage	10V
Assembly	26650 - 4S27P
Operating Temp	
Charge	0°C ~ +45°C
Discharge	-20°C ~ +60°C
Storage	-20°C ~ +45°C
Operating Humidity Range	5% - 85%
Case Material	ABS
Termination	F18 (M8 Bolt)
Series Connection	Up to 4S
Parallel Connection	No
Barcode	 9319632530566

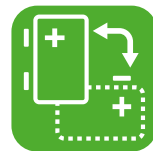

Any orientation - Drypower Rechargeable Lithium batteries with cylindrical LiFePO4 cells inside can be used and mounted in any orientation, offering ultimate flexibility in a wide variety of applications.

DIMENSIONS

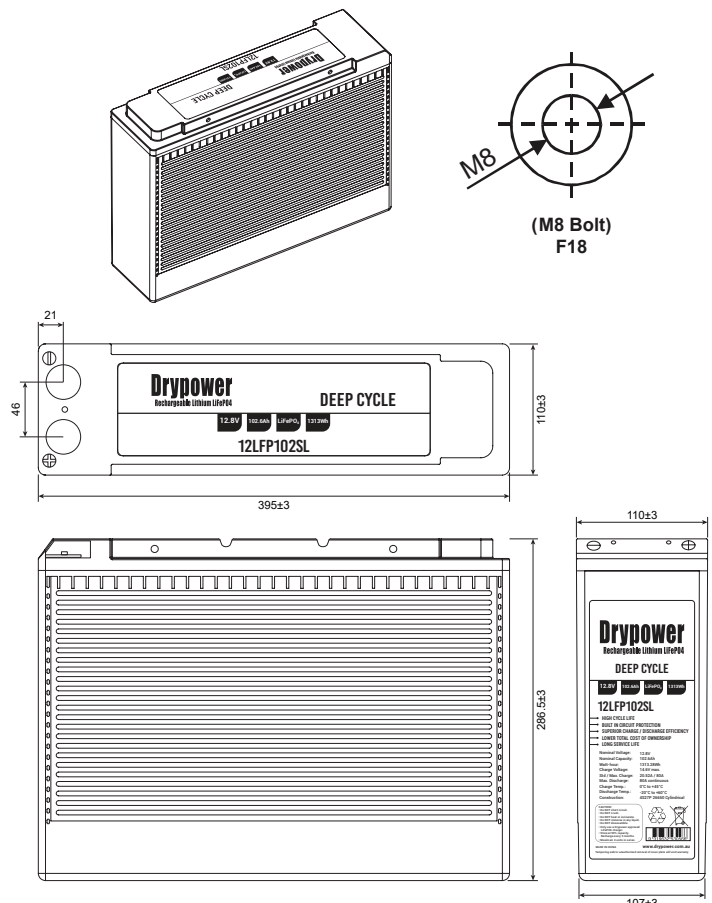

CHARACTERISTICS CHARTS

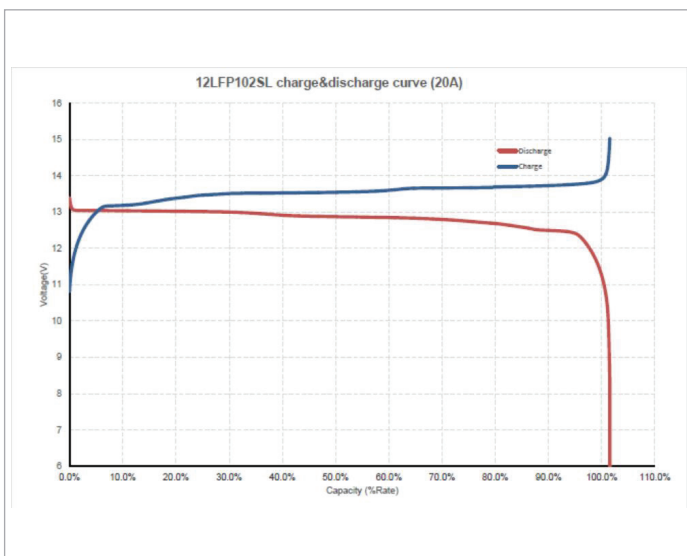
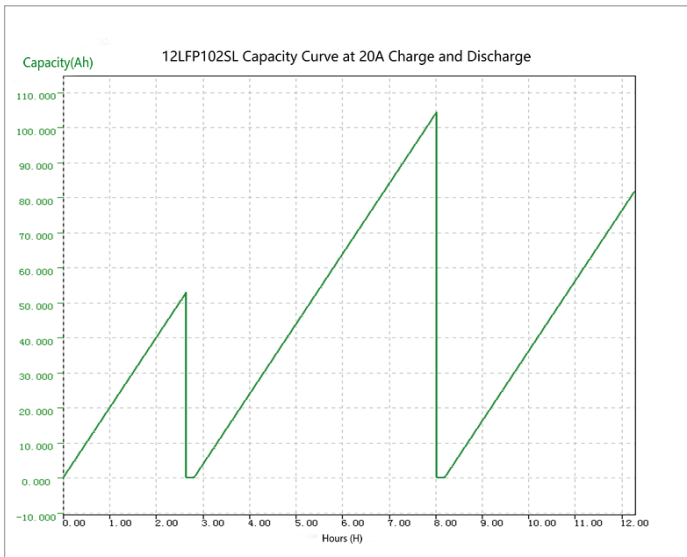
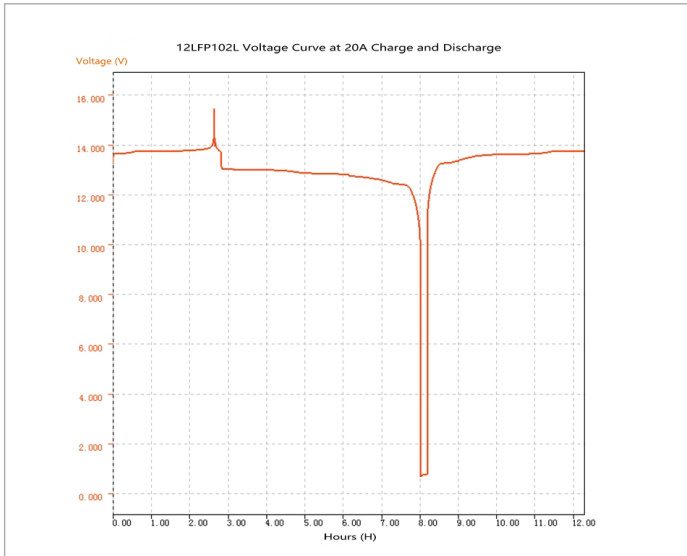

FEATURES & BENEFITS



High Cycle Life

>2000 cycles @100% DoD, 20~30°C for effectively lower total cost of ownership.



High Energy Density

Over 2X more energy density at around 1/3 the weight and half the volume of equivalent lead acid.



Superior Discharge Efficiency

With a consistently flat discharge curve, maintaining good, consistent power delivery for longer.



Built-in Circuit Protection

Battery Management Systems (BMS) are incorporated to maintain safety and prevent damage.



Better Shelf Life

12-18+ months thanks to its extremely low self discharge (LSD) rate and no risk of sulphation.



Quickly Recharge

Save time and increase productivity with less down time thanks to superior charge/discharge efficiency.



Wide Operating Temperature Tolerance

Suitable for use in a wider range of applications where ambient temperature is unusual: from -20°C up to +60°C.

BUILT IN PROTECTION

All Drypower Rechargeable Lithium batteries adhere to strict safety guidelines by incorporating Battery Management Systems (BMS) that include protection components such as:

- Integrated Circuit (IC)
- Thermistor
- MOSFET
- Protection Circuit Module (PCM)
- Fuse

The BMS in each Drypower battery helps to:

1. Maintain safety for users.
2. Prevent damage to equipment and property.
3. Eliminate concerns about use of the wrong type of charger.
4. Minimise the risk of overdischarge causing damage.
5. Provide short circuit and overcharge protection.

SUITABLE APPLICATIONS

Lithium Iron Phosphate can be used in any application that would normally use Lead Acid, GEL or AGM type batteries*. LiFePO4 in 4S = 12.8V and 8S = 25.6V is closest to Lead Acid equivalents of the lithium rechargeable types.

Suitable applications include caravan, marine, electric vehicles, golf carts & buggies, solar energy storage, remote monitoring, switching applications and more.

**Exceptions may apply so please consult with a Drypower technical expert for more information regarding your application.*

CAUTIONS

- Do NOT short circuit, crush or disassemble.
- Do NOT heat or incinerate.
- Do NOT immerse in any liquid.
- Only use a Drypower approved LiFePO4 charger.
- Store at 50% capacity. Recharge every 3 months. The storage area should be clean, cool, dry and ventilated.
- Maximum 4 units in series. No parallel connection allowed.

Tampering and/or unauthorised removal of cover plate will void warranty.

Performance may vary depending on application. All specifications are correct at time of creation. All specifications and operation conditions contained in this datasheet are subject to change or improvement without prior notice to the user. This data is for evaluation purposes only. No guarantee is intended or implied by this data. For clarification and updated information, please contact us • Aug2020